

PLASTIC THREAD PROTECTORS

STEEL THREAD PROTECTORS

***PACKING FRAMES FOR DRILL PIPES,
TUBINGS & CASINGS***

FLANGE PROTECTORS

PIPE CAPS

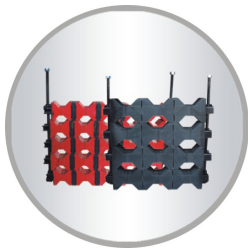

REVATA ENGINEERING

W-20, 'S' Block, M.I.D.C., Bhosari, Pune - 411026, India

Phone: +91-20-32533825

E-mail: info@revataengineering.com Web: www.revataengineering.com

Thread protector for Tubing (Composite type - Steel is inserted in plastic, CENL)



Item	Size & Thread	Item	Size & Thread
1	2 3/8" NU	6	3 1/2" EU
2	2 3/8" EU	7	4 1/2" NU
3	2 7/8" NU		
4	2 7/8" EU		
5	3 1/2" NU		

Thread protector for Tubing (Plastic type)



Item	Size & Thread	Item	Size & Thread
1	2 3/8" NU	18	5 1/2" BC
2	2 3/8" EU	19	5 1/2" (Premium Thread Protector)
3	2 3/8" NU (Premium Thread Protector)	20	6 5/8" BC
4	2 7/8" NU	21	6 5/8" (Premium Thread Protector)
5	2 7/8" EU	22	7" STC
6	2 7/8" (Premium Thread Protector)	23	7" LC
7	3 1/2" NU	24	7" BC
8	3 1/2" EU	25	7 5/8" STC
9	3 1/2" (Premium Thread Protector)	26	7 5/8" LC
10	4 1/2" NU	27	7 5/8" BC
11	4 1/2" EU	28	8 5/8" STC
12	4 1/2" STC	29	8 5/8" LC
13	4 1/2" LC	30	8 5/8" BC
14	4 1/2" BC	31	9 5/8" STC
15	4 1/2" (Premium Thread Protector)	32	9 5/8" LC
16	5 1/2" STC	33	9 5/8" BC
17	5 1/2" LC		

Thread protector for Tubing & Casing (Composite type - Steel shell & Plastic inside, CEL)

Item	Size & Thread	Item	Size & Thread
1	4" NU	19	8 5/8" LC
2	4" EU	20	8 5/8" BC
3	4" LC	21	8 5/8" (Premium Thread Protector)
4	4 1/2" STC	22	9 5/8" STC
5	4 1/2" LC	23	9 5/8" LC
6	4 1/2" BC	24	9 5/8" BC
7	4 1/2" (Premium Thread Protector)	25	9 5/8" (Premium Thread Protector)
8	5 1/2" STC	26	10 3/4" STC
9	5 1/2" LC	27	10 3/4" BC
10	5 1/2" BC	28	10 3/4" (Premium Thread Protector)
11	5 1/2" (Premium Thread Protector)	29	11 3/4" (Premium Thread Protector)
12	7" STC	30	12 7/8" (Premium Thread Protector)
13	7" LC	31	13 3/8" STC
14	7" BC	32	13 3/8" BC
15	7" (Premium Thread Protector)	33	13 3/8" (Premium Thread Protector)
16	7 5/8" (Premium Thread Protector)	34	13 5/8" BC
17	8 1/8" (Premium Thread Protector)	35	16" BC
18	8 5/8" STC		

Thread protector for Tubing & Casing - PIN (Composite type - Steel shell & Plastic inside, CENL)

Item	Size & Thread	Item	Size & Thread
1	2 3/8" NU	20	6 5/8" STC
2	2 3/8" EU	21	6 5/8" LC
3	2 3/8" (Premium Thread Protector)	22	6 5/8" BC
4	2 7/8" NU	23	6 5/8" (Premium Thread Protector)
5	2 7/8" EU	24	7" STC
6	2 7/8" (Premium Thread Protector)	25	7" LC
7	3 1/2" NU	26	7" BC
8	3 1/2" EU	27	7" (Premium Thread Protector)
9	4 1/2" STC	28	7 5/8" STC
10	4 1/2" LC	29	7 5/8" LC
11	4 1/2" BC	30	7 5/8" BC
12	4 1/2" (Premium Thread Protector)	31	7 5/8" (Premium Thread Protector)
13	5" LC	32	9 5/8" (Premium Thread Protector)
14	5" STC	33	9 7/8" (Premium Thread Protector)
15	5" BC	34	13 3/8" (Premium Thread Protector)
16	5" (Premium Thread Protector)	35	13 5/8" (Premium Thread Protector)
17	5 1/2" STC	36	13 3/4" STC
18	5 1/2" LC	37	13 3/4" BC
19	5 1/2" (Premium Thread Protector)	38	20" BC

Thread protector for Drill Pipe (composite type, CE)

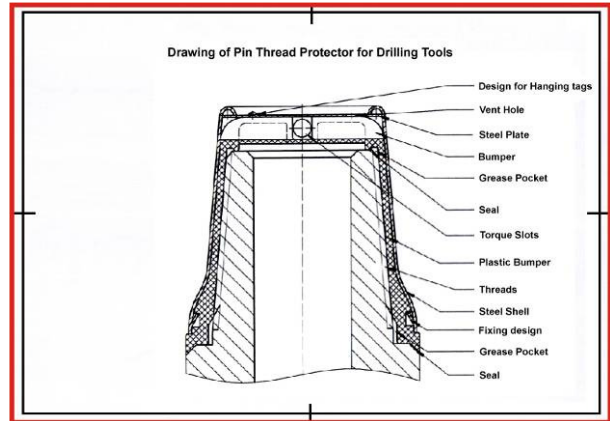
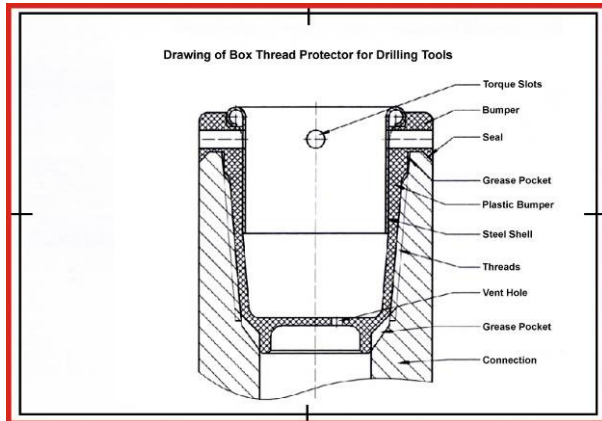

Item	Size & Thread	Item	Size & Thread
1	NC26	12	NC61
2	NC31	13	NC70
3	NC35	14	2 7/8" REG
4	NC38	15	3 1/2" REG
5	NC38 DSTJ	16	4 1/2" REG
6	NC40	17	6 5/8" REG
7	NC44	18	7 5/8" REG
8	NC46	19	8 5/8" REG
9	NC50	20	5 1/2" FH
10	NC50 DSTJ	21	5 1/2" FH DSTJ
11	NC56	22	6 5/8" FH

Thread protector for Drill Pipe (plastic type, CE)



Item	Size & Thread	Item	Size & Thread
1	NC23	14	NC70
2	NC26	15	2 3/8" REG
3	NC31	16	2 7/8" REG
4	NC35	17	3 1/2" REG
5	NC38	18	4 1/2" REG
6	NC38 DSTJ	19	6 5/8" REG
7	NC40	20	7 5/8" REG
8	NC44	21	8 5/8" REG
9	NC46	22	6 5/8" IF
10	NC50	23	5 1/2" FH
11	NC50 DSTJ	24	5 1/2" FH DSTJ
12	NC56	25	6 5/8" FH
13	NC61		

Packaging frame for Tubing & Casing

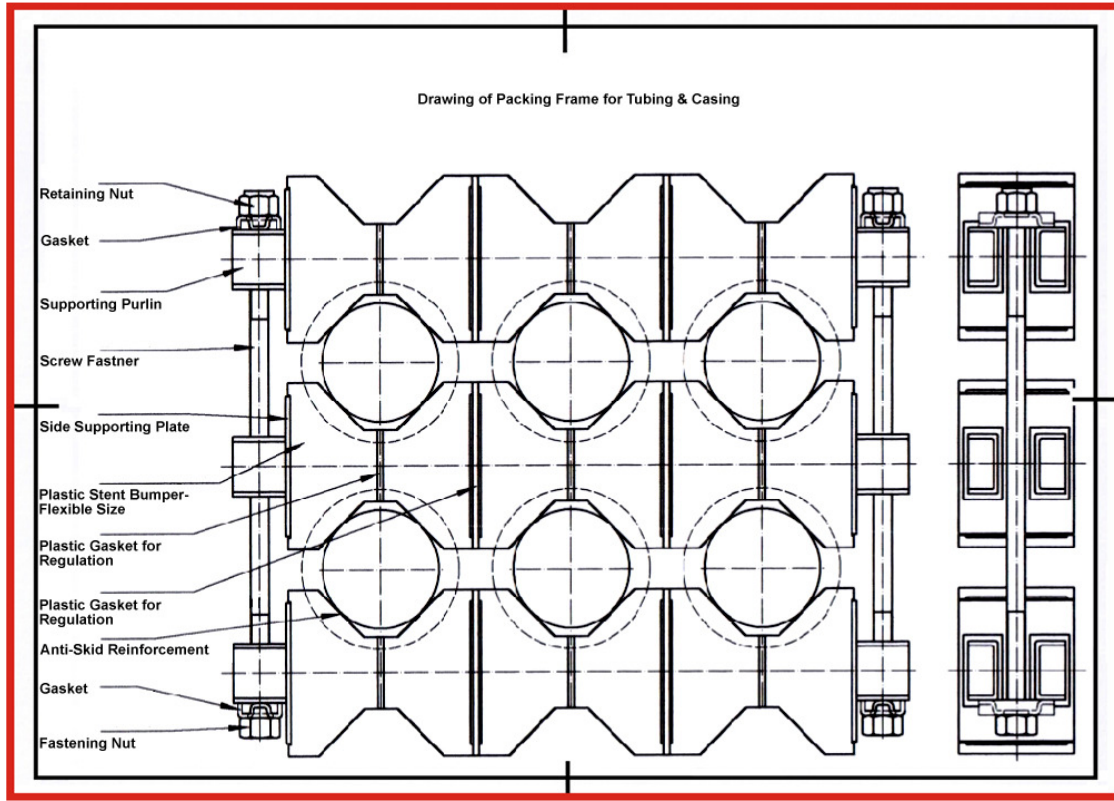

Item	Size	Item	Size
1	2 3/8"	6	5"
2	2 7/8"	7	5 1/2"
3	3 1/2"	8	6 5/8"
4	4"	9	7"
5	4 1/2"		

Packaging frame for Heavy Drill Pipe

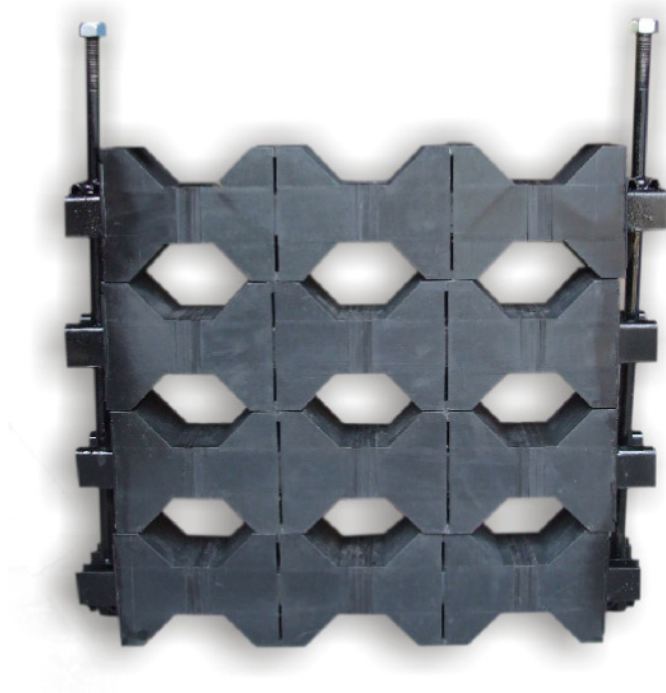

Item	Size	Item	Size
1	ZH-JZ66 – 6 5/8 FH-I	5	ZH-JZ35 – NC38-I
2	ZH-JZ55 – 6 5/8 FH-I	6	ZH-JZ29 – NC31-I
3	ZH-JZ50 – NC50-I	7	ZH-JZ50 – NC50-II
4	ZH-JZ45 – NC46-I	8	ZH-JZ45 – NC46-II

Packaging frame for Drill Pipe (Standard Size)

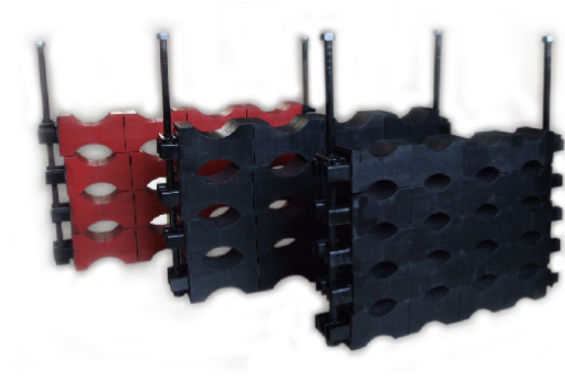
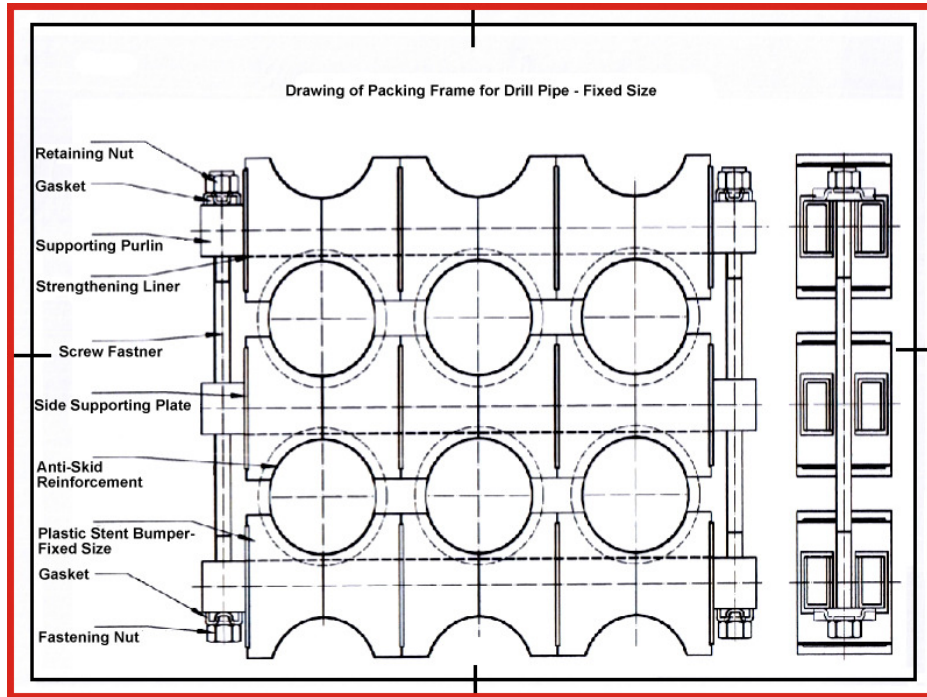

Item	Size & Thread	Item	Size & Thread
1	2 3/8" (NC26)	5	4 1/2" (NC46)
2	2 7/8" (NC31)	6	5" (NC50)
3	3 1/2" (NC38)	7	5 1/2" (5 1/2"FH)
4	4" (NC40)		

Packaging frame for Drill Pipe (Common)

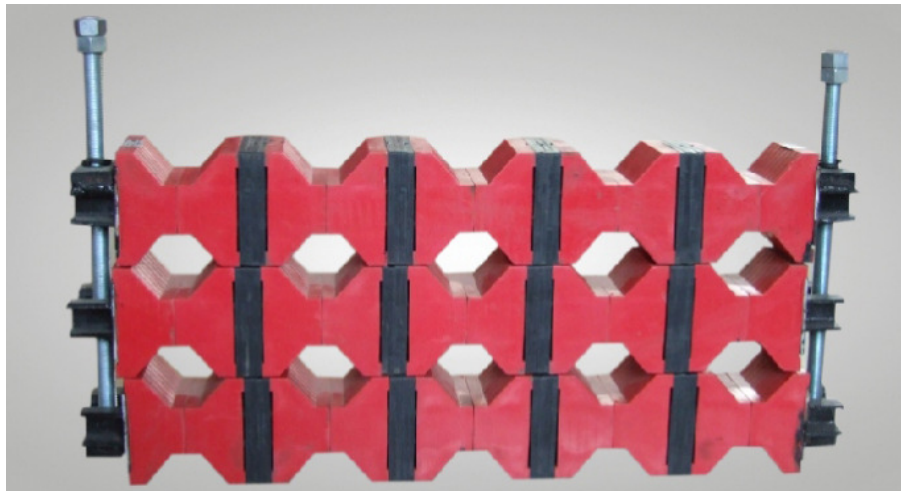
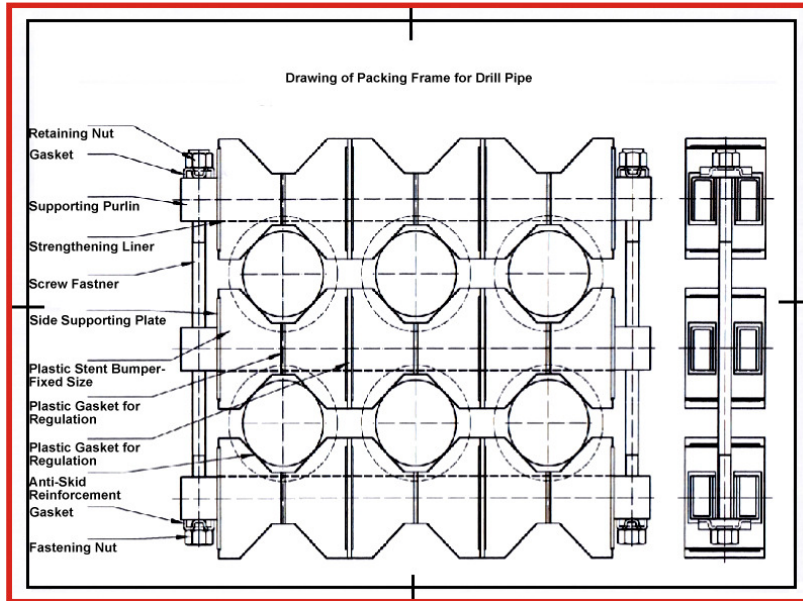

Item	Size & Thread	Item	Size & Thread
1	2 3/8"	5	4 1/2"
2	2 7/8"	6	5"
3	3 1/2"	7	5 1/2"
4	4"		

Pressed Steel Thread Protectors



Designed to protect the API drill pipes, drill collars connection and tubings made as per API 5D-7 and 5CT respectively.

Revata Engineering's Pressed Steel Thread Protectors are designed & manufactured to protect the API Drill pipes, Drill Collars connections and tubing made as per API 5D, 7&5CT respectively.

Features:

- Maximum Protection for tool joint threads.
- Maximum Protection for tool joint seals.
- Maximum Protection from Corrosion.
- Impact Protection during handling & transportation.

Revata Engineering's pressed Steel Protectors are made from 3mm thick E.D.D. QUALITY Steel sheets and machined with precision using CNC machines.

The protectors then undergo Manganese Phosphating & Dehydrating to make them rust free.

Manganese Phosphating- a hot Phosphating process adopted by Revata Engineering reduces galling, improves adhesion of thread compound & prevents steel to steel contact which helps protect functional properties of thread ends.

Hot Phosphating is just one more reason why Revata Engineering pressed Steel Thread Protectors are more preferred by the customers.

Our ranges of thread protectors are specially designed to protect the pipe thread & ends during normal handling & transportation.

The standard Threads and Sizes available are:

Item	Size & Thread	Item	Size & Thread
1	2 ^{3/8} " EUE	21	4 ^{1/2} " XH
2	2 ^{7/8} " EUE	22	4 ^{1/2} " FH
3	3 ^{1/2} " EUE	23	2 ^{7/8} " HTPAC
4	4 ^{1/2} " EUE	24	3 ^{1/2} " FH
5	2 ^{3/8} " REG	25	4" FH
6	2 ^{7/8} " REG	26	5 ^{1/2} " FH
7	3 ^{1/2} " REG	27	6 ^{5/8} " FH
8	4 ^{1/2} " REG	28	NC 23
9	5 ^{1/2} " REG	29	NC 26
10	6 ^{5/8} " REG	30	NC 31
11	6 ^{5/8} " REG	31	NC 35
12	2 ^{3/8} " IF	32	NC 38
13	2 ^{7/8} " IF	33	NC 40
14	3 ^{1/2} " IF	34	NC 44
15	4 " IF	35	NC 46
16	4 ^{1/2} " IF	36	NC 50
17	5 ^{1/2} " IF	37	NC 56
18	2 ^{7/8} " PAC	38	NC 61
19	2 ^{7/8} " PAC DS	39	NC 70
20	5 ^{1/2} " FH DSTJ	40	NC 77

Tubular / Pipe End Caps & Protectors



Revata Engineering manufactures a wide range of Pipe End Caps / End Protectors for Tubulars / Pipes used in various industries. These are manufactured in LDPE, LLDPE, PP, PE and also in various Metals based on customer requirements.

They are also used for many other applications to cover open tubing holes in various equipment during transportation or storage to avoid foreign objects entering the equipment and causing it to malfunction or get damaged.

WE MANUFACTURE END CAPS / PROTECTORS FROM SIZES STARTING FROM A FEW MILIMETERS RIGHT UPTO 72" (SEVENTY TWO INCHES).

- ✦ End Protection Caps allows your manufactured products to arrive at their destination in the same condition that they left in.
- ✦ End Protection Caps will save you the cost and time that will come from rejects and it is a way to have inexpensive insurance for your manufactured products.
- ✦ End Protection Caps are to protect and cover the ends of pipe from being damage in storage, shipping, transit, and before installation.
- ✦ It keeps the inside pipe clean from dirt, debris, and animals.
- ✦ The protectors can last for years because the plastic is UV resistant to sun and age. Caps can be closed or open end, custom designed, and fabricated to your specific needs.
- ✦ Special caps for odd sized pipe, extra-large, square, and rectangular end pipe is also available.
- ✦ Plastic see through lenses can be added on the cap to see inside the pipe. We can mount desiccant bags inside the cap to absorb moisture and reduce humidity.
- ✦ **METAL END CAPS / END PROTECTORS** are also available on all the below sizes.

We manufacture End Caps / End Protectors in the following standard sizes:

Product Description	Size (In Inches)	Product Description	Size (In Inches)
End Caps / End Protectors	1.5	End Caps / End Protectors	26
End Caps / End Protectors	2	End Caps / End Protectors	28
End Caps / End Protectors	3	End Caps / End Protectors	30
End Caps / End Protectors	4	End Caps / End Protectors	32
End Caps / End Protectors	5	End Caps / End Protectors	34
End Caps / End Protectors	6	End Caps / End Protectors	36
End Caps / End Protectors	8	End Caps / End Protectors	42
End Caps / End Protectors	10	End Caps / End Protectors	48
End Caps / End Protectors	12	End Caps / End Protectors	54
End Caps / End Protectors	14	End Caps / End Protectors	56
End Caps / End Protectors	16	End Caps / End Protectors	60
End Caps / End Protectors	18	End Caps / End Protectors	72
End Caps / End Protectors	20		
End Caps / End Protectors	22		
End Caps / End Protectors	24		

Flange Protectors – LDPE / LLDPE / Foam



Revata Engineering manufactures a wide range of Flange Protectors / Flange Covers to suit the requirements of various applications and Industries.

These are manufactured in Special LDPE and PP materials. We can also manufacture based on your specific designs and material requests.

Flange Protectors are available in various types such as:

- ✦ Stud Hole Fitting Flange Protectors
 - ✦ EVA Foam Flange Protectors
 - ✦ SAE High Pressure Flange Covers
 - ✦ Bolted Quick Fit Flange Covers
 - ✦ SAE High Pressure Flange Covers
 - ✦ Push-In Flange Covers
 - ✦ Integral Arrow Clip Flange Disks
 - ✦ Full Face Flange Covers
 - ✦ Full Face Disks - Pressboard Flange Protectors
 - ✦ Full Face Disks - HDPE Flange Protectors
 - ✦ Raised Face Flange Plug Flange Protectors
-
- ✦ **Flange Protectors are used to protect flange faces from damage during storage, shipping and handling.**
 - ✦ **They reduce the chances of rejections thus saving precious time.**
 - ✦ **Flange Protectors are available in various sizes and for ASME Class (Lb) 150#, 300#, 600#, 900#, 1500#, 3000#, 5000#, 60000#.**
 - ✦ **We can also manufacture based on your specific designs, materials and sizes.**

We manufacture and stock Flange Protectors / Flange Covers in the following standard sizes:

Product Description	Flange Size (In Inches)	Available in ASME Class (Lb)
Flange Protectors / Flange Covers	1.5	150#, 300#, 600#, 900#, 1500#, 5000#
Flange Protectors / Flange Covers	2	150#, 300#, 600#, 900#, 1500#, 5000#
Flange Protectors / Flange Covers	3	150#, 300#, 600#, 900#, 1500#, 5000#
Flange Protectors / Flange Covers	4	150#, 300#, 600#, 900#, 1500#, 5000#
Flange Protectors / Flange Covers	5	150#, 300#, 600#, 900#, 1500#, 5000#
Flange Protectors / Flange Covers	6	150#, 300#, 600#, 900#, 1500#, 5000#
Flange Protectors / Flange Covers	8	150#, 300#, 600#, 900#, 1500#, 5000#
Flange Protectors / Flange Covers	10	150#, 300#, 600#, 900#, 1500#, 5000#
Flange Protectors / Flange Covers	12	150#, 300#, 600#, 900#, 1500#, 5000#
Flange Protectors / Flange Covers	14	150#, 300#, 600#, 900#, 1500#, 5000#
Flange Protectors / Flange Covers	16	150#, 300#, 600#, 900#, 1500#, 5000#
Flange Protectors / Flange Covers	18	150#, 300#, 600#, 900#, 1500#, 5000#
Flange Protectors / Flange Covers	20	150#, 300#, 600#, 900#, 1500#, 5000#
Flange Protectors / Flange Covers	22	150#, 300#, 600#, 900#, 1500#, 5000#
Flange Protectors / Flange Covers	24	150#, 300#, 600#, 900#, 1500#, 5000#
Flange Protectors / Flange Covers	26	150#, 300#, 600#, 900#, 1500#, 5000#
Flange Protectors / Flange Covers	28	150#, 300#, 600#, 900#, 1500#, 5000#
Flange Protectors / Flange Covers	30	150#, 300#, 600#, 900#, 1500#, 5000#
Flange Protectors / Flange Covers	32	150#, 300#, 600#, 900#, 1500#, 5000#
Flange Protectors / Flange Covers	34	150#, 300#, 600#, 900#, 1500#, 5000#
Flange Protectors / Flange Covers	36	150#, 300#, 600#, 900#, 1500#, 5000#
Flange Protectors / Flange Covers	42	150#, 300#, 600#, 900#, 1500#, 5000#
Flange Protectors / Flange Covers	48	150#, 300#, 600#, 900#, 1500#, 5000#
Flange Protectors / Flange Covers	54	150#, 300#, 600#, 900#, 1500#, 5000#
Flange Protectors / Flange Covers	56	150#, 300#, 600#, 900#, 1500#, 5000#
Flange Protectors / Flange Covers	60	150#, 300#, 600#, 900#, 1500#, 5000#
Flange Protectors / Flange Covers	72	150#, 300#, 600#, 900#, 1500#, 5000#



REVATA ENGINEERING

W-20, 'S' Block,
M.I.D.C., Bhosari,
Pune - 411026, India

Phone: +91-9561612158

E-mail: info@revataengineering.com

Web: www.revataengineering.com